

Custom Angle Scenic Post Installation

Residential installation only. Commercial applications may differ.
Always check with local building codes prior to purchasing and installing this product.
Scenic Series railing may not be approved as a guard railing in some jurisdictions. Check with your local building inspection authority prior to purchasing to ensure this product is code compliant for your intended usage.

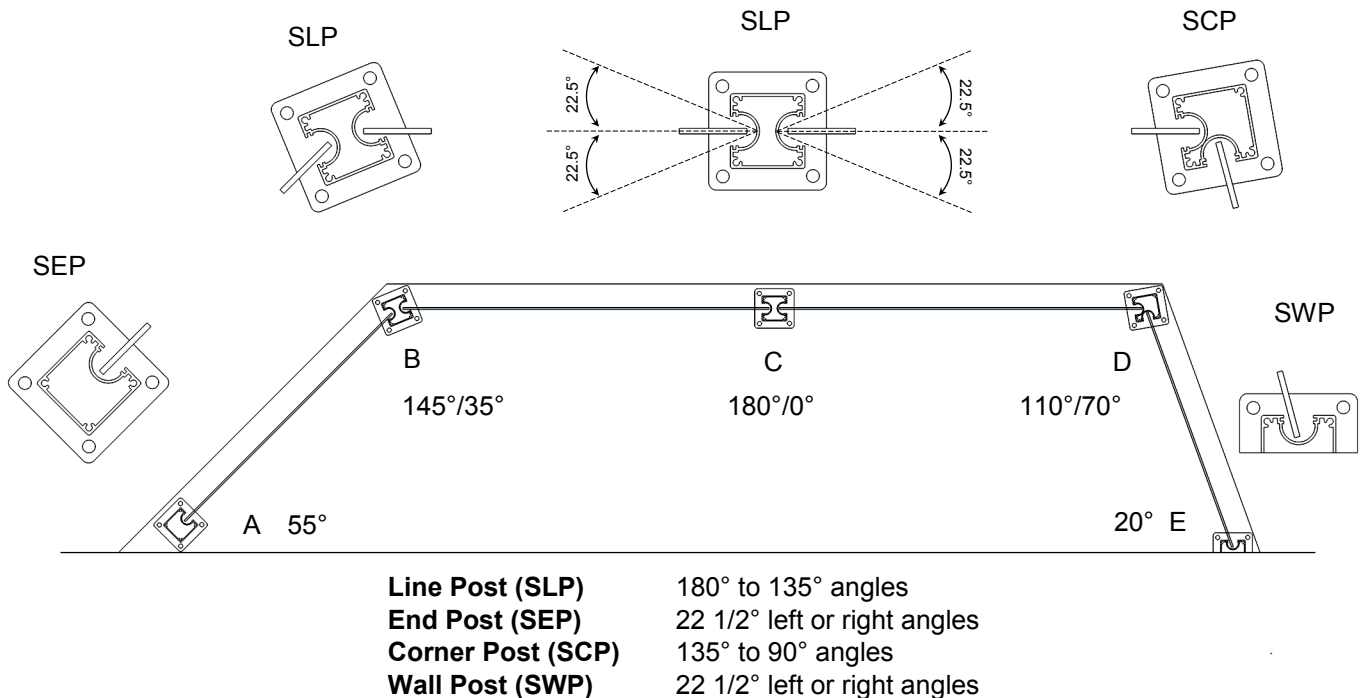

A. Scenic End Post (SEP) required.

Since this angle is 55° from the wall, (which exceeds the maximum angle of 22.5° allowed by the post) a Scenic End Post (SEP) aligned straight with the glass needs to be used.

B. Scenic Line Post (SLP) required.

The corner of the deck at this point is 145°/35°. Use a Scenic Line Post (SLP) installed with the baseplate turned evenly in the middle of the angle. This will split the angle into two 17.5° angles from each side of the post.

C. Scenic Line Post (SLP) required.

The straight section of the deck requires a Scenic Line Post (SLP) installed in line with the edge of the deck.

D. Scenic Corner Post (SCP) required

The corner of the deck at this point is 110°/70°. Use a Scenic Corner Post (SCP) installed with the baseplate turned evenly in the middle of the angle. This will split the angle into two 10° angles from each side of the post.

E. Scenic Wall Post (SWP) required.

Since this angle is only 20° from the wall, use a Scenic Wall Post (SWP) mounted flush against the wall. A Scenic Wall Post allows for angles up to 22.5° left or right.

When Scenic Railing is being used as a guardrail, do not exceed the 48" center to center spacing as this is outside our engineering spec and is at the end users own risk and could result in a failed inspection. It is the sole responsibility of the home owner/contractor to comply with local building codes.