

# 5/8" x 5/8" x 8' Component Picket Railing - Surface Mount

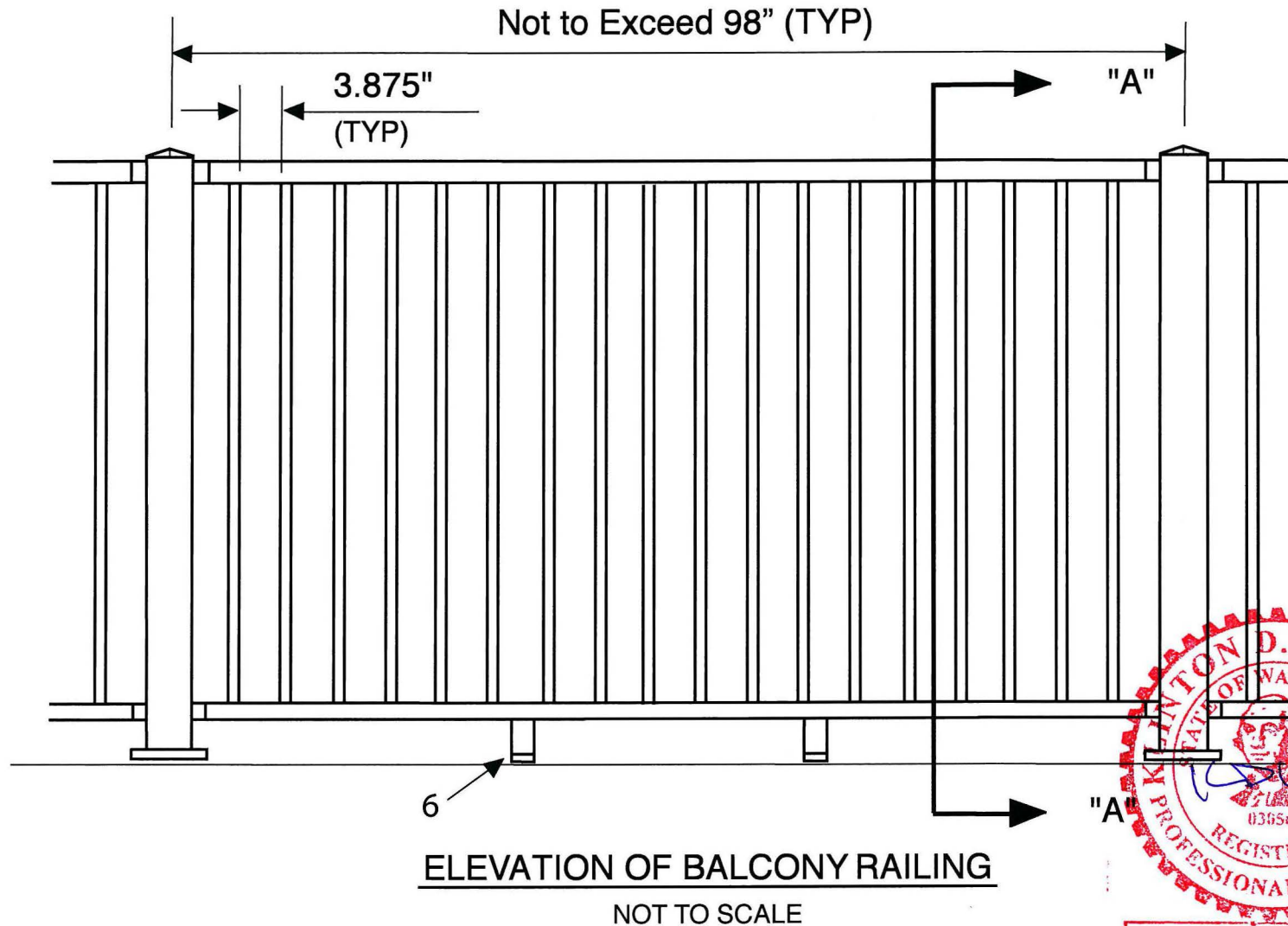

Note: Post to Substrate fastening detail is not within the scope of this drawing

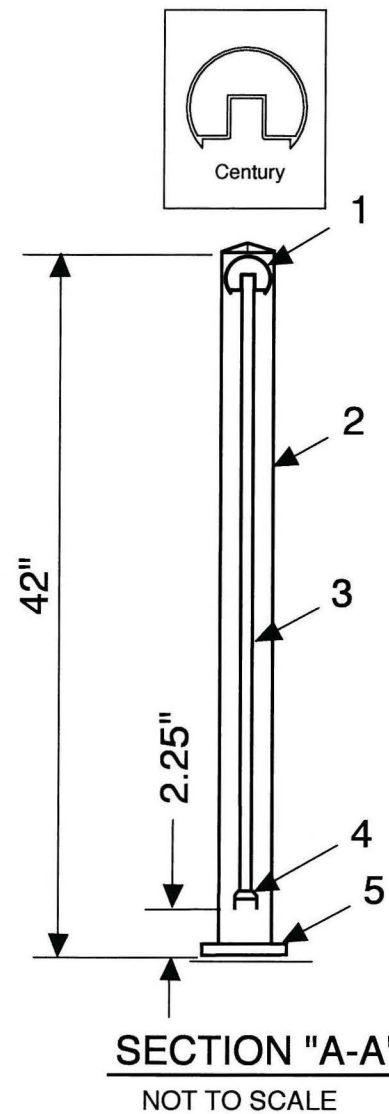
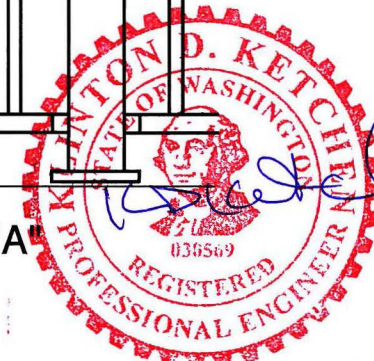

EXPIRES 10/31/2016

APR 20 2016  
Alloy

NOTE: THE STRUCTURES INCLUDED WITHIN THE SCOPE OF THIS DRAWING HAVE BEEN DESIGNED IN ACCORDANCE WITH THE REQUIREMENTS OF THE 2015 IRC.



A DIVISION OF CENDEK RAILINGS LTD.

9685 Agur St., Summerland, B.C. V0H 1Z2

Phone: (778) 516-6250 • Fax: (778) 516-6003 • Toll Free: 1-888-493-1103

	Material - Aluminum	Thickness	Alloy
1	Top Rail - Century 2.35" x 1.89	.083	6063-T54
2	Post - 2.50" x 2.50"	.075	6063-T54
3	Picket - .625" x .625"	.050	6063-T54
4	Bottom Rail - 1.06" x 1.41"	.070	6063-T54
5	Baseplate - 4" x 4"	.250	6005A-T6
6	Support Leg	.125	6063-T54